

A
view without cover

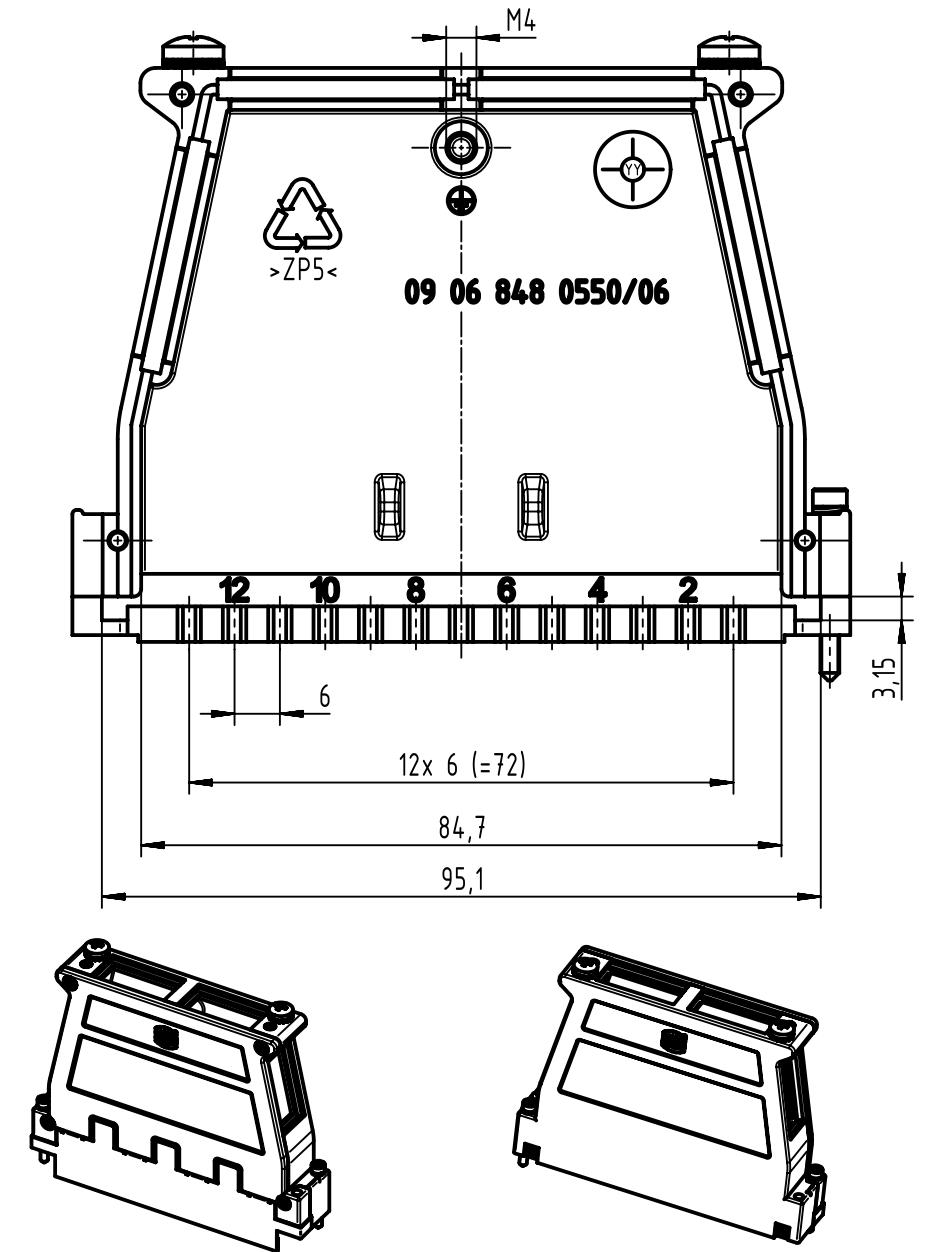

content shell housing			spare parts	
pos.	qty	description	part no.	qty
01	1	casing shell		
02	1	casing cover		
03	2	locking screw with tip M2.5x23	09 06 800 9953	1
04	4	countersunk head screw ISO 14581 M2.5x10-T8	09 06 800 9960	1
05	2	pan head screw ISO 7045-M4x8-A2-70-Z	09 06 800 9958	1
06	1	shielding cover		

All Dimensions in mm Original Size DIN A3	Scale	Free size tol.		Ref.	
	1:1			Sub.	
All rights reserved Department EC PD - DE	Created by	Inspected by	Standardisation	Date	State
	STORCK	TADJE	HOFFMANN	2017-09-01	Final Release
Title			Doc-Key / ECM-Nr.		
DIN Power shell housing D20 metal			100719377/UGD/000/B 500000124527		
Type		Number	Rev.	Page	
TB		09068480556	B	1/1	