



DIN signal male connector with special contacts



General information

Design	IEC 60603-2	types: M invers male
No. of contacts (signal+special)	78+2, 60+4, 42+6, 24+8, 6+10	
Contact spacing	2,54 mm for signal contacts	7,62 mm for special contacts
Test voltage	1000V	
Contact resistance	max. 20mOhm for crimp termination	
	max. 15mOhm for wire wrap	
Insulation resistance	min. 10 ¹⁰ Ohm	
Working current	2A at 20°C (see derating diagram) for signal contacts for special contacts refer to corresponding data sheet	
Temperature range	-55°C ... +125°C -40°C ... +105°C for press-in connectors (due to limitations of PCB material)	
Termination technology	solder pins, press-in, wirewrap	
Clearance & creepage distance	min. 1,2mm	
Insertion and withdrawal force without special contacts	6pole max. 6N	42pole max. 40N
	24pole max. 23N	60pole max. 57N
		78pole max. 74N
Mating cycles	PL 1 acc. to IEC 60603-2	500 mating cycles
	PL 2 acc. to IEC 60603-2	400 mating cycles
	PL 3 acc. to IEC 60603-2	50 mating cycles
UL file	E102079	
RoHS - compliant	Yes	
Leadfree	Yes	
Hot plugging	No	

Insulator material

Material	PBT (thermoplastics, glass fiber reinforcement 30%)
Color	RAL 7032 (grey)
UL classification	UL 94-V0
Material group acc. IEC 60664-1	IIIa (175 ≤ CTI < 400)
NFF classification	I3, F4

Contact material

Contact material	Copper alloy
Plating termination zone signal contacts	S over Ni for solder, Ni for press-in, Ni for wirewrap
Plating contact zone signal contacts	Au over PdNi over Ni
Plating special contacts	refer to corresponding data sheet

Derating diagram acc. to IEC 60512-5 (Current carrying capacity)

The current carrying capacity is limited by maximum temperature of materials for inserts and contacts including terminals.

The current capacity curve is valid for continuous, non interrupted current loaded contacts of connectors when simultaneous power on all contacts is given, without exceeding the maximum temperature.

Control and test procedures according to DIN IEC 60512-5

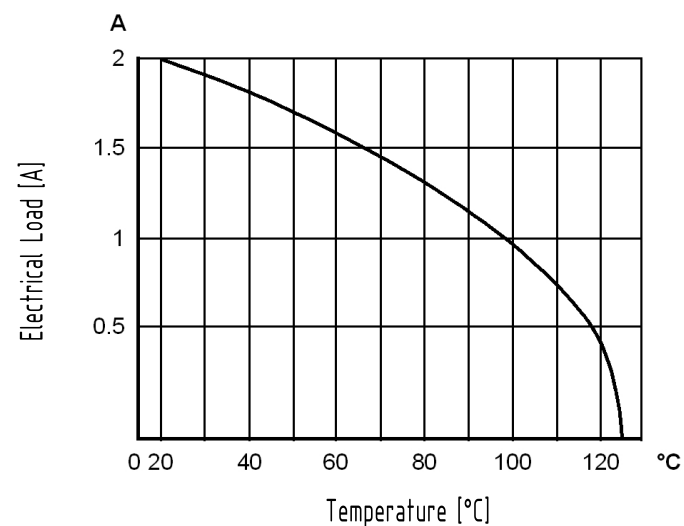

Recommended configuration of plated through holes for press-in termination

In addition to the hot-air-level (HAL), other PCB surfaces are getting more important. Due to their different properties - such as mechanical strength and coefficient of friction - we recommend the following configuration of PCB through holes.

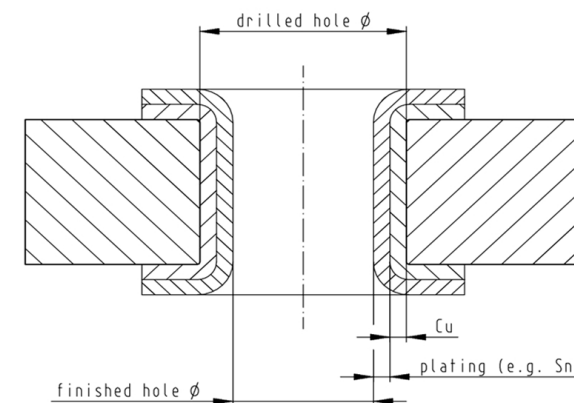

PCB Type	Layer	Thickness / Diameter
Tin plated PCB (HAL) acc. to EN 60352-5	Drilled hole Ø	1,15±0,025mm
	Cu	min. 25 µm
	Sn	max. 15µm
Chemical tin plated PCB	Drilled hole Ø	1,15±0,025 mm
	Cu	min. 25 µm
	Sn	min. 0,8 µm
Gold /Nickel plated PCB	Drilled hole Ø	1,15±0,025 mm
	Cu	min. 25 µm
	Ni	3-7 µm
Silver plated PCB	Drilled hole Ø	1,15±0,025 mm
	Cu	min. 25 µm
	Ag	0,1 - 0,3 µm
Copper plated PCB (OSP)	Drilled hole Ø	1,15±0,025 mm
	Cu	min. 25 µm
	plated hole Ø	1,00 - 1,10 mm

Assembly instructions

It is highly recommended to use HARTING press-in tools to ensure a reliable press-in process. Please refer to the catalogue for tools, machines and further information about the press-in process.

Soldering instructions

The connectors should be protected when being soldered in a dip, flow or film soldering baths. Otherwise, they might become contaminated as a result of soldering operations or deformed as a result of overheating.

(1) For prototypes and short runs protect the connectors with an industrial adhesive tape, e.g. Tesaband 4331 (www.tesa.de). Cover the underside of the connector moulding and the adjacent parts of the pcb as well as the open sides of the connector. This will prevent heat and gases of the soldering apparatus from damaging the connector. About 140 + 5 mm of the tape should suffice.

(2) For large series a jig is recommended. Its protective cover with a fast action mechanical locking device shields the connectors from gas and heat generated by the soldering apparatus. As an additional protection a foil can be used for covering the parts that should not be soldered.

Cross section of solder terminations

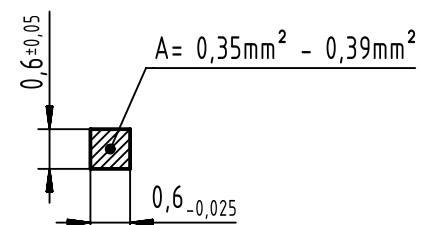

	All Dimensions in mm Original Size DIN A3	Scale 1:1	Free size tol.	Ref. Sub. DS 09 73 110 00 02 Mod. EC01482 2011-04-29	
	All rights reserved Department EC PD - DE	Created by KAHLERK	Inspected by TADJE	Standardisation HOFFMANN	Date 2014-08-01
Title DIN signal male connector with special contacts				State Final Release	
HARTING Electronics GmbH D-32339 Espelkamp		Type DS	Number 09731100002	Doc-Key / ECM-Nr. 100580759/UGD/000/A 50000076060	
				Rev. A	Page 1/1