

A-A (10:1)

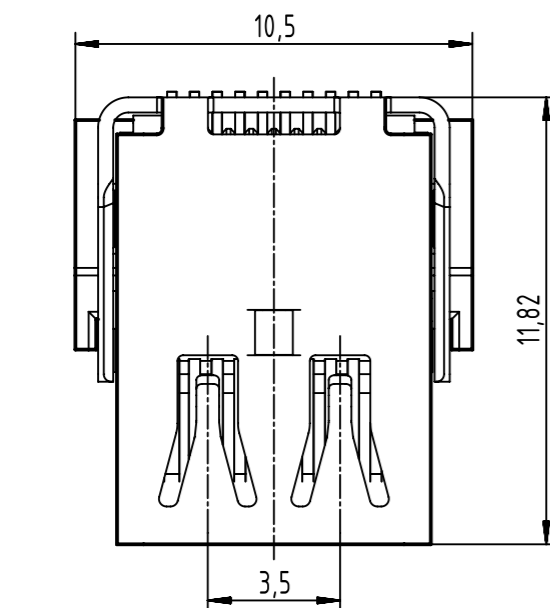

packaging direction for solder jacks in tape & reel

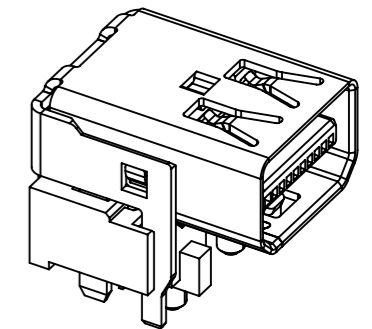
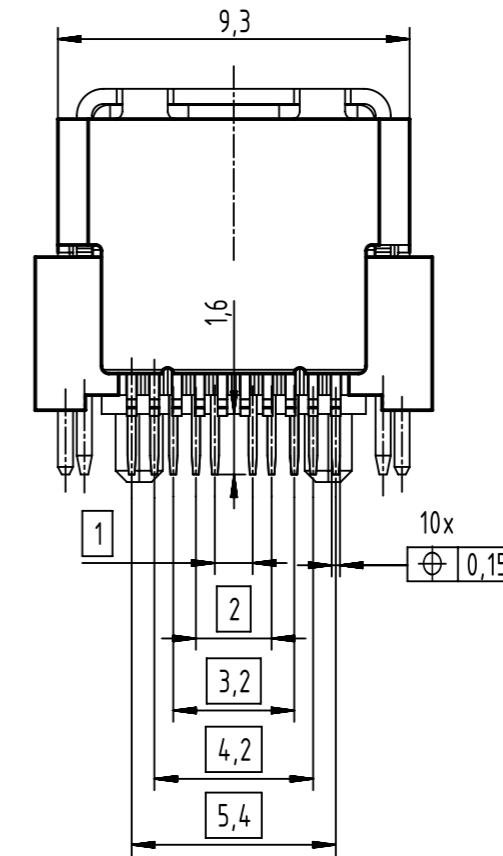
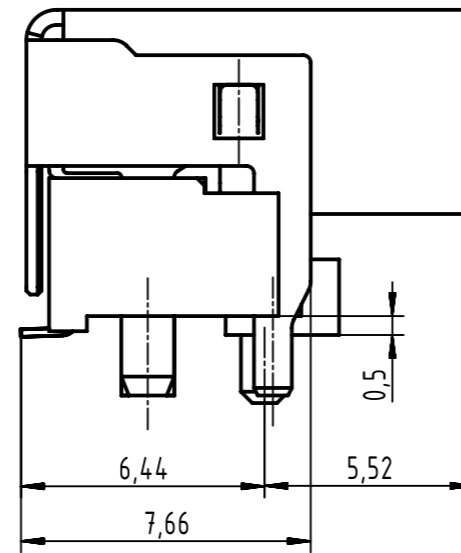
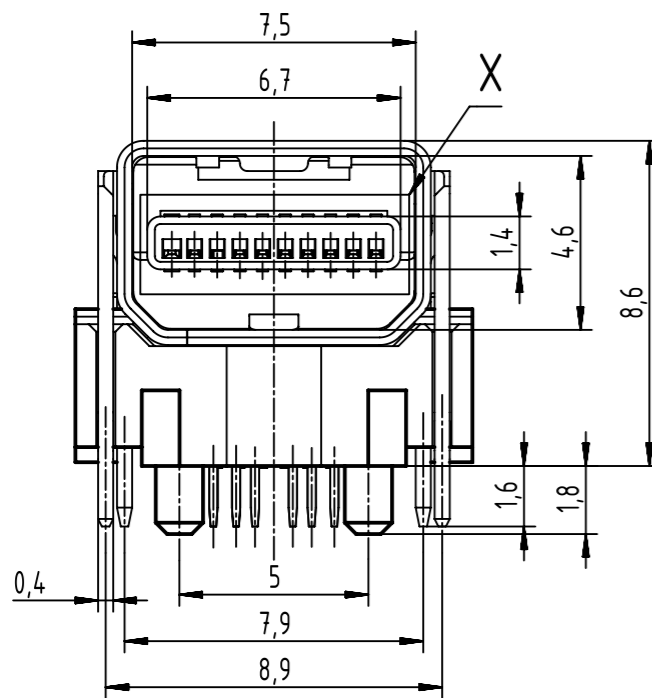
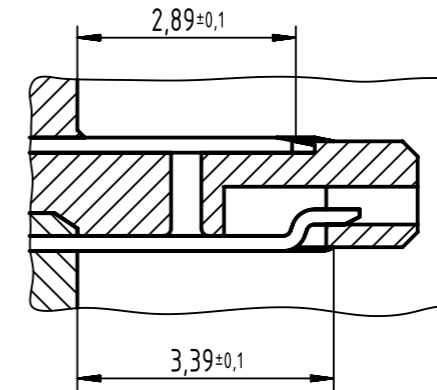
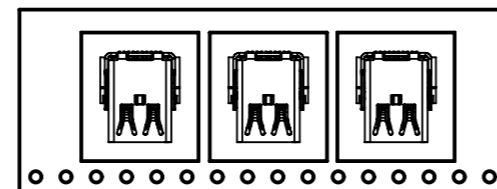

direction of movement

further information see: DS 0945000001

	All rights reserved Department EC PD - DE	All Dimensions in mm Original Size DIN A3		Scale 5:1	Free size tol.	Ref. Sub.
		Created by ZWAHR	Inspected by ELLERMANN	Standardisation HOFFMANN	Date 2018-05-03	State Final Release
HARTING Electronics GmbH D-32339 Espelkamp		Title Mini DisplayPort receptacle			Doc-Key / ECM-Nr. 100658727/UGD/000/B 500000134674	
		Type TB	Number 09455511000		Rev. B	Page 1/2

PCB layout

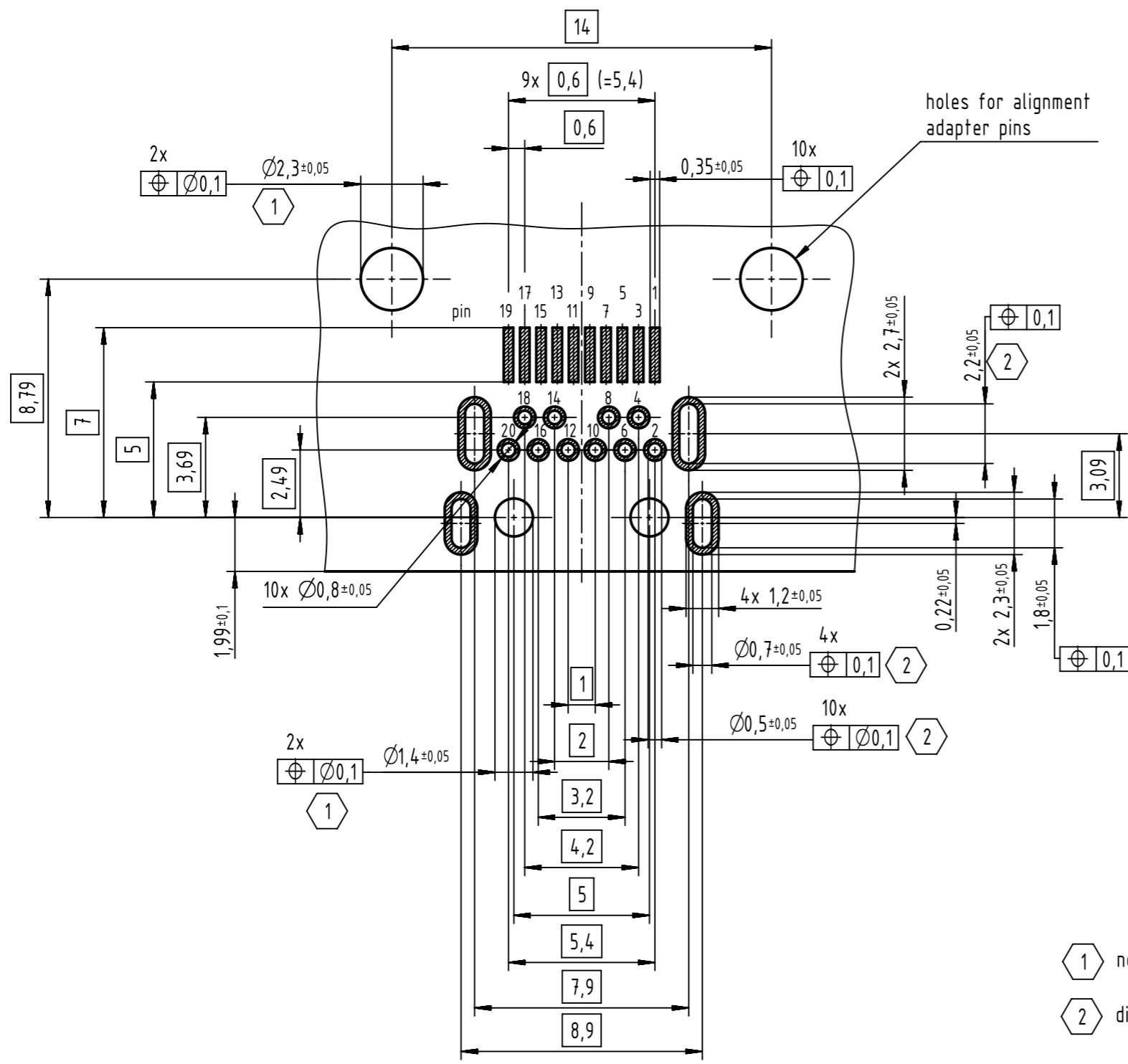

holes for alignment adapter pins

Pin Number	Pin Name - Source Side	Pin Name - Sink Side
1	GND	GND
2	Hot Plug Detect	Hot Plug Detect
3	ML_Lange0(p)	ML_Lange3(n)
4	CONFIG 1	CONFIG 1
5	ML_Lange0(n)	ML_Lange3(p)
6	CONFIG 2	CONFIG 2
7	GND	GND
8	GND	GND
9	ML_Lange1(p)	ML_Lange2(n)
10	ML_Lange3(p)	ML_Lange0(n)
11	ML_Lange1(n)	ML_Lange2(p)
12	ML_Lange3(n)	ML_Lange0(p)
13	GND	GND
14	GND	GND
15	ML_Lange2(p)	ML_Lange1(n)
16	AUX_CH(p)	AUX_CH(p)
17	ML_Lange2(n)	ML_Lange1(p)
18	AUX_CH(n)	AUX_CH(n)
19	GND	GND
20	DP_PWR(PWR OUT)	DP_PWR(PWR OUT)

- 1 non metallized
- 2 dimension after metallization process

	All rights reserved		Created by ZWAHR		Inspected by ELLERMANN		Standardisation HOFFMANN		Date 2018-05-03		State Final Release	
	Department EC PD - DE		Title Mini DisplayPort receptacle		Type TB		Number 09455511000		Doc-Key / ECM-Nr. 100658727/UGD/000/B 500000134674		Rev. B Page 2/2	
All Dimensions in mm Original Size DIN A3			Scale 5:1		Free size tol.		Ref.		Sub.			
HARTING Electronics GmbH D-32339 Espelkamp												