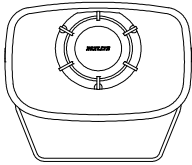
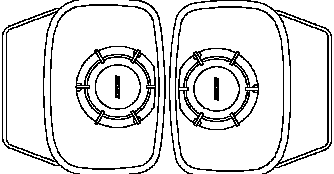
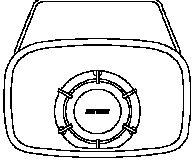

<h1>SPECIFICATIONS</h1>
-------------------------

## 1. Specifications

### 1-1. General Specification

Product Name	Melody/Alarm Horn		
Model	EHS-M1		
Rated Voltage	DC12 V-DC 24V		
Operating Voltage Range	DC10.8 V-DC 35V		
Rated Current Consumption	Max.	450mA	
Rated Power Consumption (for NPN/No-voltage)	Typ.	5.0W (at DC 12 V)	
	Conditions	At maximum volume and "Rapid Hi-Lo" alarm playback	
	Max.	5.2W (at DC 12 V)	
	Conditions	At maximum volume and "Rapid Hi-Lo" alarm playback	
Rated Power Consumption (for PNP/Voltage Input)	Typ.	5.9W (at DC 12 V)	
	Conditions	At maximum volume and "Rapid Hi-Lo" alarm playback	
	Max.	7.6W (at DC 31.6 V)	
	Conditions	At maximum volume and "Rapid Hi-Lo" alarm playback	
Inrush Current	4A or less (at DC12 V)		
	9A or less (at DC24 V)		
	12.5A or less (at DC35 V)		
Operating Ambient Temperature	-20 °C to +50 °C		
Operating Ambient Humidity	Less than 85% (No condensation)		
Storage Ambient Temperature	-30 °C to +60 °C		
Storage Ambient Humidity	Less than 85% (No condensation)		
Mounting Location	Indoors/Outdoors		
Mounting Direction	Upright	Sideways	Upside-down
			
Protection Rating	IP65 (IEC 60529)		
Environmental Condition	Upright Installation		
Vibration Resistance	45.0m/s <sup>2</sup> IEC 60068-2-6:2007 (Upright Position)		
Insulation Resistance	More than 1MΩ at 500VDC between the terminals and the chassis		
Withstand Voltage	500VAC applied for 1min between terminals and chassis without breaking insulation		
Sound Pressure Level	Maximum: 110 dB		
Environmental Condition	Upright position from horn opening at a distance of 1m. Volume at maximum and "Stutter" alarm played		
Impact Resistance	250m/s <sup>2</sup> 6ms for 1,000 times (3 axis 1 direction); 500m/s <sup>2</sup> 11ms for 3 times (3 axis both directions) IEC 60068-2-27:2008 (Upright Position)		
Mass (Tolerance ±10%)	1.25kg		
Outer Dimensions	7. Outer Dimensions		
Supported Memory Card	SD Card / SDHC Card Recommended Parts: SDV-2GP (option)		
SD Card Format	FAT 16, 32		
Compliance Standards	EMC Directive (EN 61000-6-4, EN 61000-6-2) RoHS Directive (EN 50581) UL 464, CSA-C22.2 No. 205-M1983 FCC Part15 SubpartB Class A KC (KN22, KN24)		
Remarks	UL Listed (File No.S24210)		

Drawing No.	Rev.	Page
EHS-W18	F	2 / 13

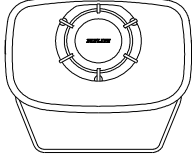
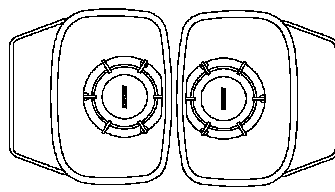
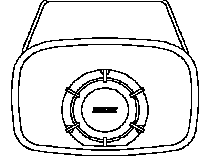
Product Name		Melody/Alarm Horn		
Model		EHS-M2		
Rated Voltage		AC100V - AC240V (50/60Hz)		
Operating Voltage Range		AC90V - AC264V (50/60Hz)		
Rated Current Consumption	Max.	140mA		
Rated Power Consumption (for NPN/No-voltage)	Typ.	6.9W (at AC 240 V)		
	Conditions	At maximum volume and "Rapid Hi-Lo" alarm playback		
	Max.	7.3W (at AC 264 V)		
	Conditions	At maximum volume and "Rapid Hi-Lo" alarm playback		
Inrush Current		6A or less (at AC 100 V)		
		15A or less (at AC 240 V)		
		23A or less (at AC 264 V)		
Operating Ambient Temperature		-20 °C to +50 °C		
Operating Ambient Humidity		Less than 85% (No condensation)		
Storage Ambient Temperature		-30 °C to +60 °C		
Storage Ambient Humidity		Less than 85% (No condensation)		
Mounting Location		Indoors/Outdoors		
Mounting Direction	Upright	Sideways	Upside-down	
				
Protection Rating		IP65 (IEC 60529)		
Environmental Condition		Upright Installation		
Vibration Resistance		45.0m/s <sup>2</sup> JIS C 60068-2-6:2010 (Upright Installation)		
Insulation Resistance		More than 1MΩ at 500VDC between the terminals and the chassis		
Withstand Voltage		1500VAC applied for 1min between terminals and chassis without breaking insulation		
Sound Pressure Level		Maximum: 110 dB		
Environmental Condition		Upright position from horn opening at a distance of 1m. Volume at maximum and "Stutter" alarm played		
Impact Resistance		250m/s <sup>2</sup> 6ms for 1,000 times (3 axis 1 direction); 500m/s <sup>2</sup> 11ms for 3 times (3 axis both directions) IEC 60068-2-27:2008 (Upright Position)		
Mass (Tolerance ±10%)		1.25kg		
Outer Dimensions		7. Outer Dimensions		
Supported Memory Card		SD Card / SDHC Card Recommended Parts: SDV-2GP (option)		
SD Card Format		FAT 16, 32		
Compliance Standards		UL 464, CSA-C22.2 No. 205-M1983 FCC Part15 SubpartB Class A KC (KN22, KN24)		
Remarks		UL Listed (File No.S24210) There are no contents of controlled substances exceeding the threshold for the RoHS Directive.		

### 1-2. Performance Specifications

Volume Control	Volume Adjustable: Min. - Max. Sound Reduction Input: It is a value specified as a reduction from the currently adjusted volume.(None, -10dB, -20dB, -30dB selection)
Sound Playback	Alarm/Melody (Fixed)
Number of Playback Channels	Bit Input: 8/binary input: 32
Alarm/Melody	8. Sound List Reference
Playback start-up time	300ms or less (Signal Input and Power Supply Startup)

### 1-3. Signal Input Specification

Signal Input Condition	Hold Input
Signal Input Priority	Channel 8 > Channel 7 > Channel 6 > Channel 5 > Channel 4 > Channel 3 > Channel 2 > Channel 1 (except for a binary input)
Contact Control Method	[EHS-M1]: Non-voltage/Voltage Contact [EHS-M2]: Non-voltage Contact
Contact Closed-Circuit Current	12mA or less
Contact Open-Circuit Voltage	【EHS-M1】: 6V or less 【EHS-M2】: 8V or less

Contact Input (Circuit Configuration)	Non-voltage Contact	Voltage Contact (EHS-M1 Only)
Transistor Input (Circuit Configuration)	NPN Transistor	PNP Transistor (EHS-M1 Only)

## 2. Model

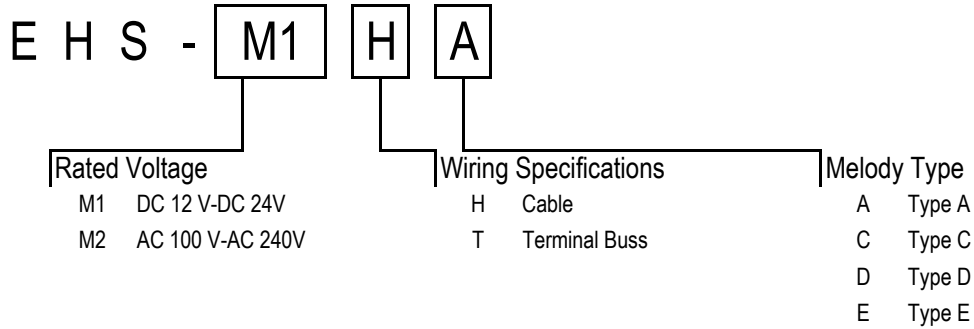

## 3. Wiring Diagram

- Non Voltage Contact

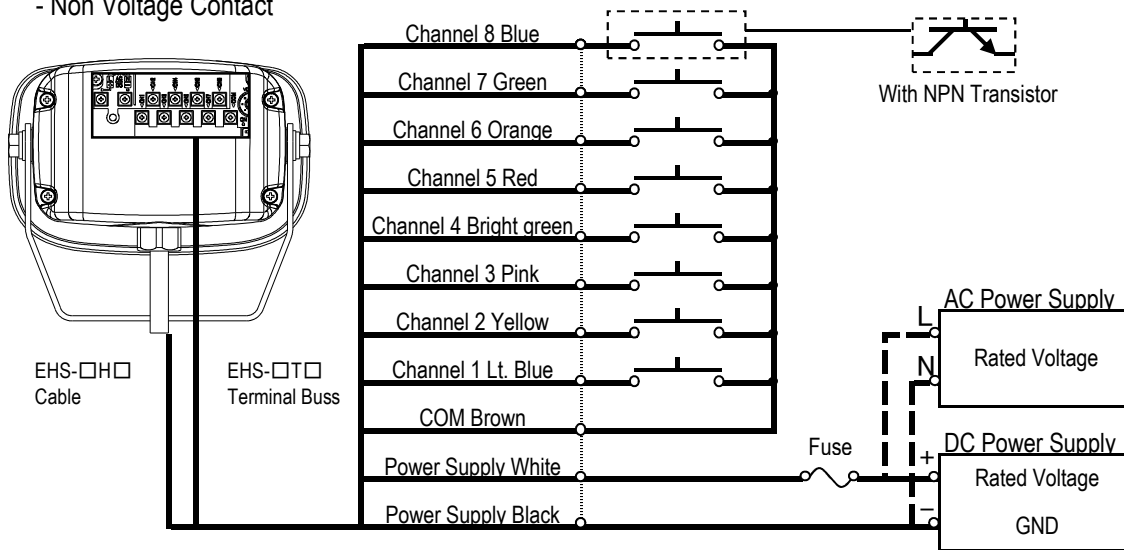

- Voltage Contact (EHS-M1 Only)

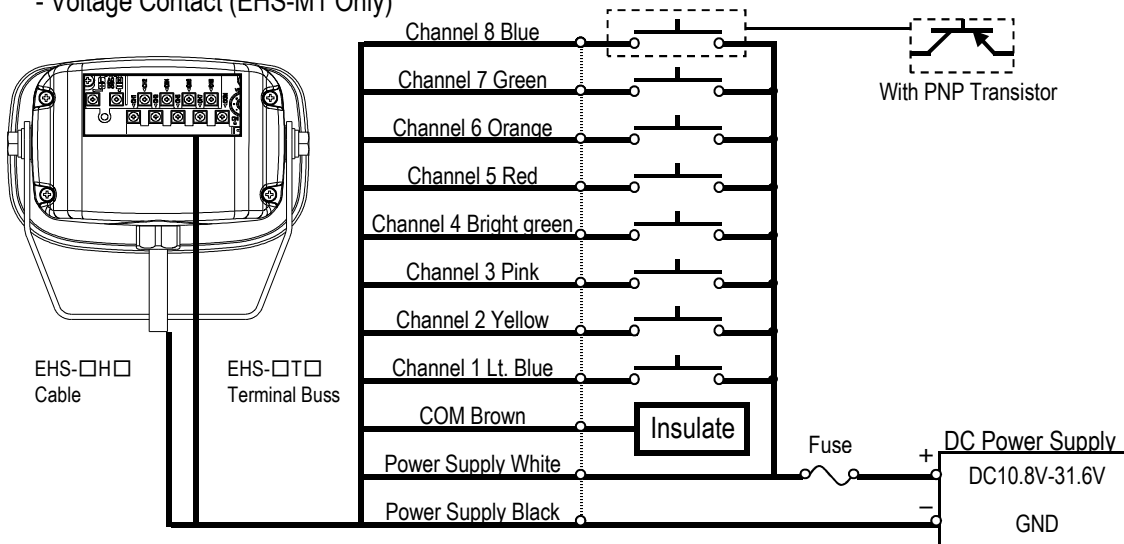

- \* Each channel color is indicated by the cable or lead wire.
- \* Voltage contact input should be in the range of DC10.8 V to DC31.6 V.
- \* When using the Terminal type model, round terminals with M3 insulated coating is recommended when wiring to the Terminal.

Recommended Parts: J.S.T. Manufacturing Co., Ltd. N1.25-3 (article corresponding to RoHS)

When connecting a Source-type PLC, be sure to insert a diode as indicated in the drawing below. Failure to insert a diode will lead to possible malfunction.

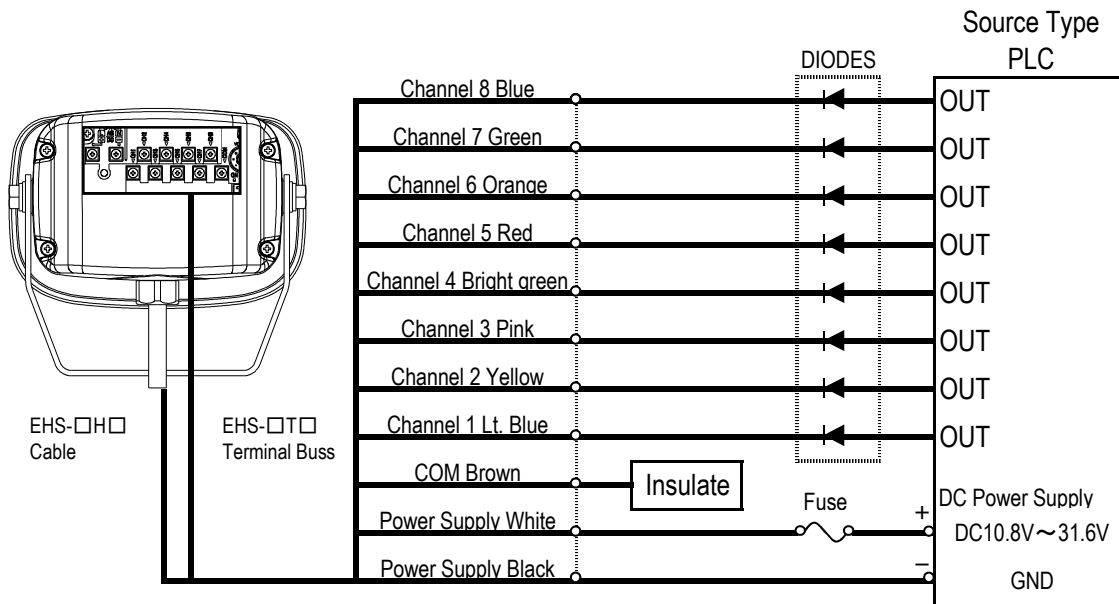

※Select a diode with ratings indicated below.

Forward Current	50mA or more
Reverse Voltage	50V or more

#### 4. Part Names and Functions

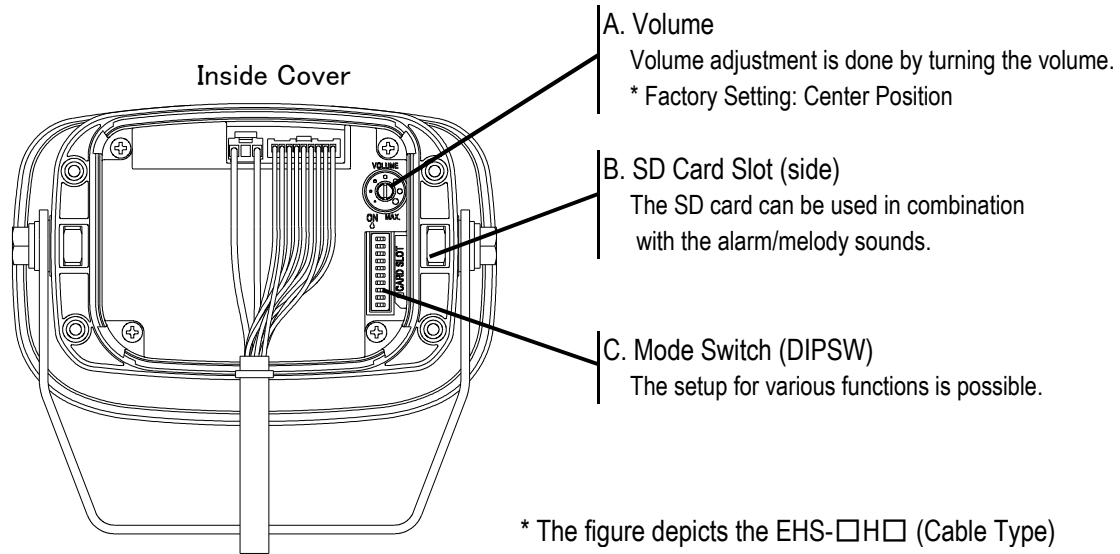

(5) Forced Playback OFF	(5) Forced Playback ON
<p>(5) Forced Playback Open</p> <p>(4) Sound Mode</p> <p>(3) Sound Reduction</p> <p>(2) Channel Input Method Open</p> <p>(1) Sound Group</p>	<p>(5) Forced Playback Open</p> <p>(4) Sound Mode</p> <p>(6) Tone Selection</p>

Mode Switch Function List

Function Name	Setting Index	Details
(1) Sound Group	Groups A-H * The user can edit sounds for group H.	Refer to "5-1. Sound Group."
(2) Channel Input Method	Binary/Bit	Refer to "5-2. Channel Input Method."
(3) Sound Reduction	No sound reduction/ -10dB/-20dB/-30dB	Refer to "5-3. Sound Reduction."
(4) Sound Mode	Factory Mode / Public Address Mode	Refer to "5-4. Sound Mode."
(5) Forced Playback	Forced Playback ON/OFF	Refer to "5-5. Forced Playback."
(6) Tone Selection	Playback Sound Selection	

Drawing No.	Rev.	Page
EHS-W18	F	7 / 13

## 5. Functionality Details

### 5-1. Sound Group

The sound groups that can be played back are selectable from eight groups of A through H with the Mode Switch (DIPSW). (For bit input)

A sound group cannot be selected when "(2) channel input method" is set for binary.

Sounds for group H can be rearranged freely.

In order to transfer the setting data, the SD card can be used for recombination and transmitting it to the product. Setting data is created as regular data in a text format and the name is saved as OTO-LIST.TXT.

Refer to "8. Sound List" for the Mode Switch (DIPSW) and sound group combination which can be selected.

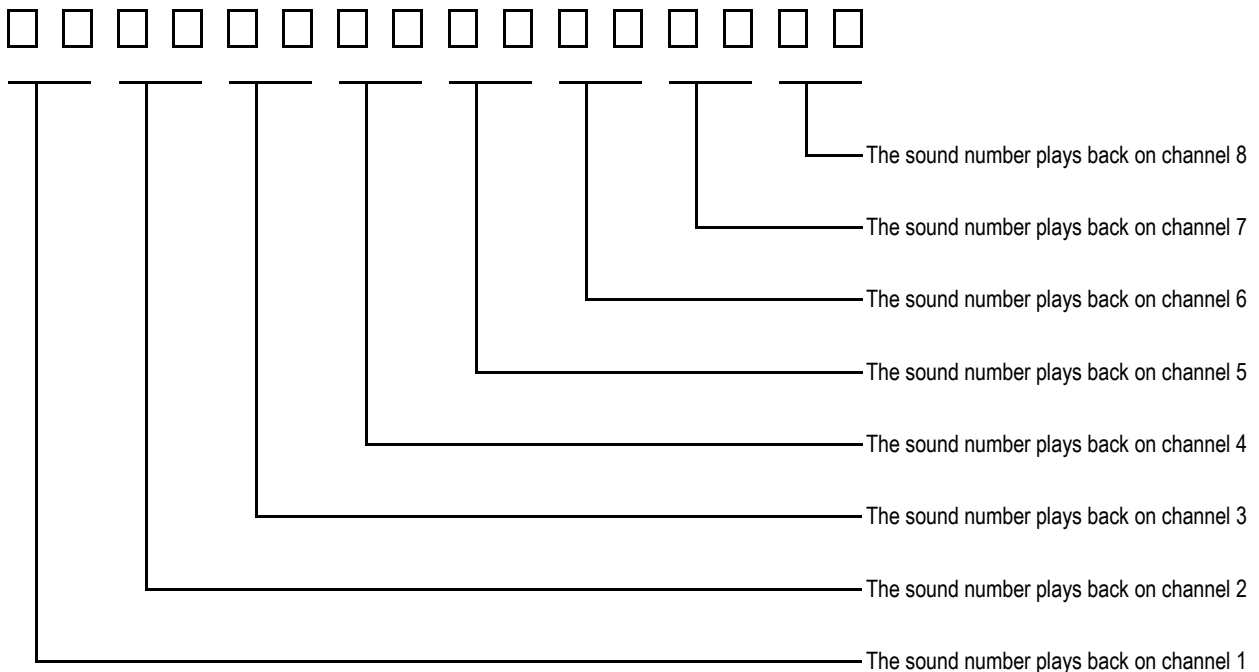

\* Refer to "8. Sound List" for the sound numbers.

\* Factory Setting: Group A

## 5-2. Channel Input Method

Channel input mode can be selected for bit/binary with the Mode Switch (DIPSW).

With the bit input, channels 1-8 can be used to reproduce up to eight channels. (When sound reduction is OFF)

With the binary input, channels 1-6 can be used to reproduce up to 32 channels.



\* Factory Setting : Bit

Binary Input Table

Sound No.	Channel								Sound No.	Channel							
	1	2	3	4	5	6	7	8		1	2	3	4	5	6	7	8
1	0								17	0				0			
2		0							18		0			0			
3	0	0							19	0	0			0			
4			0						20			0		0			
5	0		0						21	0		0		0			
6		0	0						22		0	0		0			
7	0	0	0						23	0	0	0		0			
8				0					24				0	0			
9	0			0					25	0			0	0			
10		0		0					26		0		0	0			
11	0	0		0					27	0	0		0	0			
12			0	0					28			0	0	0			
13	0		0	0					29	0		0	0	0			
14		0	0	0					30		0	0	0	0			
15	0	0	0	0					31	0	0	0	0	0			
16					0				32						0		

0 -- Switch ON



### 5-3. Sound Reduction

#### - (5) Forced Playback OFF

With the sound reduction function turned ON, when a signal input is put on channel 8, the sound level is reduced at playback.

The sound pressure for the sound reduction can be preset. (-10dB,-20dB,-30dB)

The Sound Reduction Function can be selected with the Mode Switch (DIPSW).

When the Sound Reduction Function is turned ON, the number of channels available for playback in the Bit Input Mode is set to seven.

\* Factory Setting: No Sound Reduction

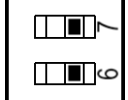
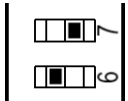
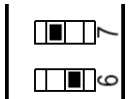
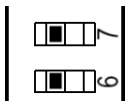
Mode Switch Condition	Sound Reduction Volume
	No Sound Reduction
	-10dB
	-20dB
	-30dB

#### - (5) Forced Playback ON

With a Forced Playback, if a signal line input occurs, the playback sound can be reduced.

The sound reduction level can be selected by the channel input.

Priority rank is channel3>channel2>channel1.

Signal Input Condition	Sound Reduction Volume
None	No Sound Reduction
Channel1	-10dB
Channel2	-20dB
Channel3	-30dB

### 5-4. Sound Mode

The alarm/melody audibility reproduction can be selected with the Mode Switch (DIPSW).

<input type="checkbox"/> <input type="checkbox"/> <input checked="" type="checkbox"/> <input type="checkbox"/> ∞	<input checked="" type="checkbox"/> <input type="checkbox"/> <input type="checkbox"/> <input type="checkbox"/> ∞
"Factory Mode"	"Public Address Mode"

- Factory Mode -- The audible sound is suitable as a warning alarm.
- PA Mode -- The audible sound is suitable for public announcements.

\* Factory Setting: "Factory Mode"

### 5-5. Forced Playback

When the Forced Playback mode is turned ON, it will play back after power is supplied, even with no signal input. It can be used for testing the playback volume or when controlled by power supply start-up. The Forced Playback is selected for ON/OFF with the Mode Switch (DIPSW). The sound (channel) to play back can be selected by the Mode Switch (DIPSW).

<input type="checkbox"/> <input type="checkbox"/> <input checked="" type="checkbox"/> <input type="checkbox"/> 10	<input checked="" type="checkbox"/> <input type="checkbox"/> <input type="checkbox"/> <input type="checkbox"/> 10
Forced Playback OFF	Forced Playback ON

\* Factory Setting: Forced Playback OFF

Sound Select Diagram

Sound No.	Mode Switch					Sound No.	Mode Switch				
	1	2	3	4	5		1	2	3	4	5
1						17					0
2	0					18	0				0
3		0				19		0			0
4	0	0				20	0	0			0
5			0			21			0		0
6	0		0			22	0		0		0
7		0	0			23		0	0		0
8	0	0	0			24	0	0	0		0
9				0		25				0	0
10	0			0		26	0			0	0
11		0		0		27		0		0	0
12	0	0		0		28	0	0		0	0
13			0	0		29			0	0	0
14	0		0	0		30	0		0	0	0
15		0	0	0		31		0	0	0	0
16	0	0	0	0		32	0	0	0	0	0

0 -- Switch ON

## 6. Timing Chart

It only plays back while the signal input is maintained.  
 Playback will be stopped as soon as the signal input is lost.  
 Repetitive playback occurs when the signal input is maintained.

- Channel Input Method : Bit Input

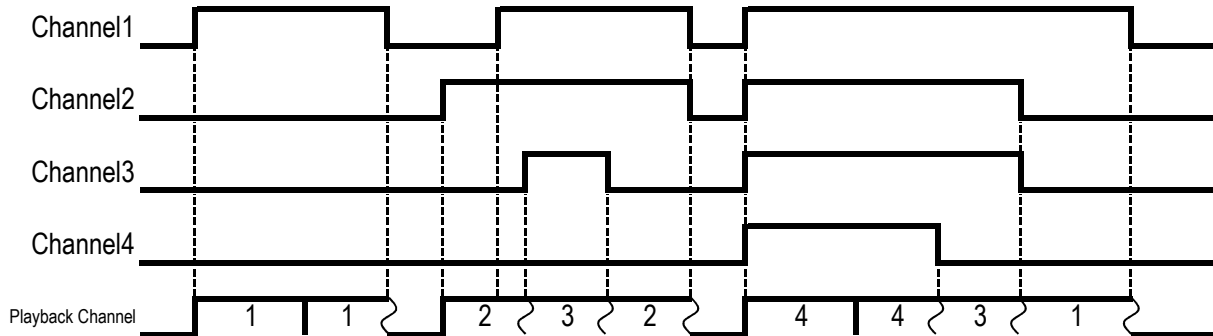

- \* All channels above 5 are the same.
- \* The wavy line indicates playback is stopped, and the channel corresponding to the changed signal input (Playback) is reproduced.

- Channel Input Method : Binary Input

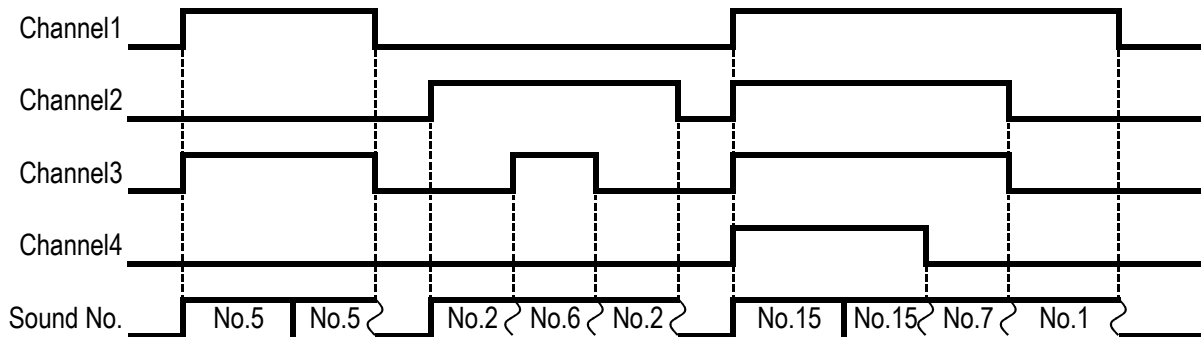

- \* All channels above 5 are the same.
- \* The wavy line indicates when playback was stopped and the sound which was the changed signal input (Playback) is played.

## 7. Outer Dimension Drawing

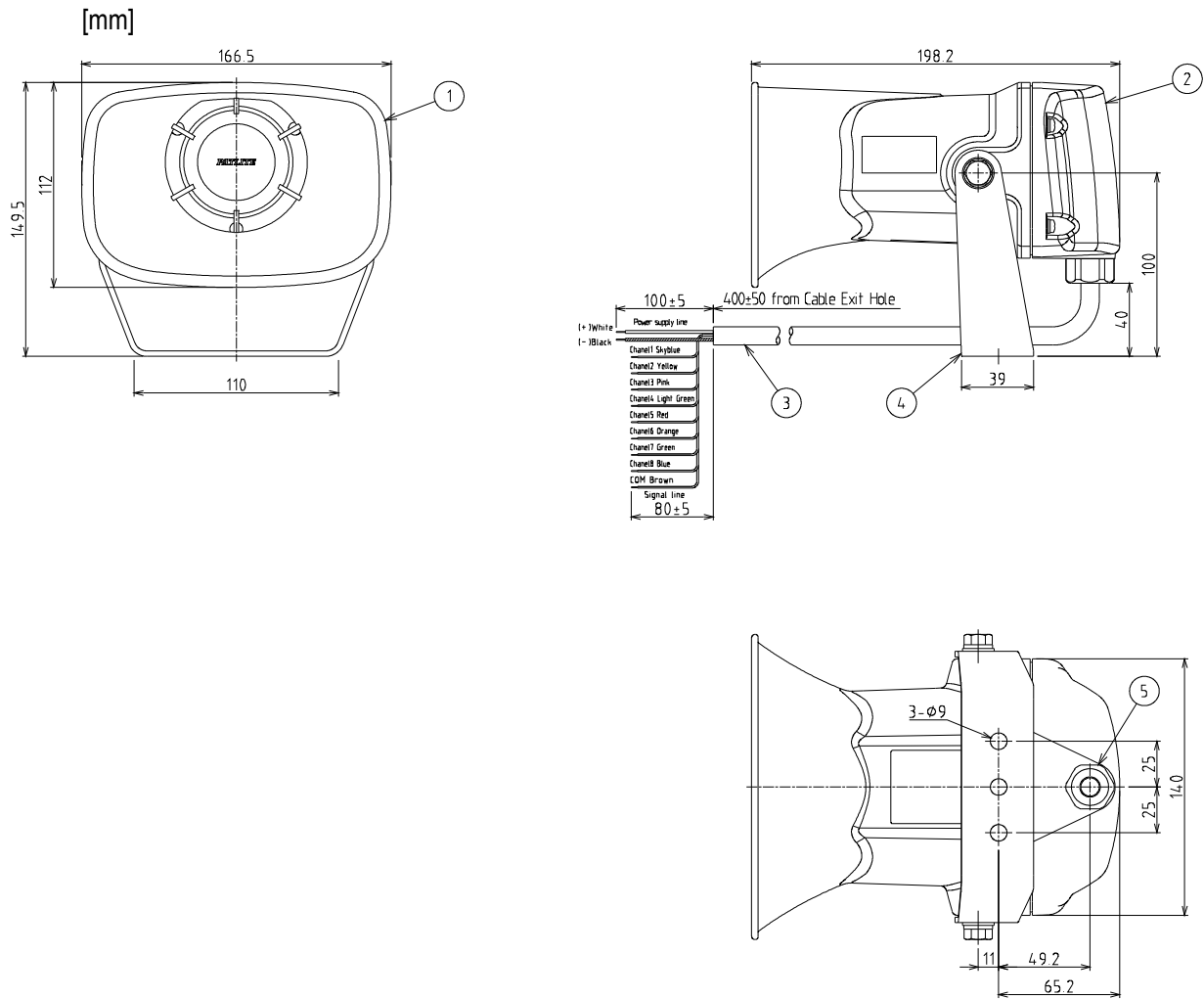

Number	Part Names	Material	Quantity
1	Case	PC	1
2	Cover	PC	1
3	Cable	UL2464 (AWG18x2C+AWG22x9C) $\phi$ 9	1*
4	Angle Bracket	SUS304 t=3.0	1
5	Waterproof Gland	PA	1

\* (3) is attached only to EHS-□H.

## 8. Sound List

Type A	01	Beep	07	Synthesized Piano	13	Fur Elise	19	Mary had a little Lamb	25	Amaryllis	31	Grandfather's Clock
	02	Stutter	08	Synthesized Bell	14	A Maiden's Prayer	20	Camptown Races	26	Mozart Symphony No.40	32	Ave Maria
	03	Bell	09	Stutter + Bell	15	Minuet in Gmjr	21	Cuckoo	27	Quiet Lakeside		
	04	Yelp	10	Synthesized Melody	16	Annie Laurie	22	Village Blacksmith	28	Mountain Musician		
	05	Rapid Hi-Lo	11	Chime	17	London Bridge is falling down	23	On the Avignon Bridge	29	Spanish Romance		
	06	Melody Chime	12	Call Sign	18	Hol-Di-Li-Dia	24	Daydream Believer	30	Katyuscha		
Type C	01	Beep	07	Synthesized Piano	13	Can't take my eyes off of You	19	Canon	25	I Don't Want to Miss a Thing	31	Ima sugu Kiss Me
	02	Stutter	08	Synthesized Bell	14	Top of the World	20	La-la Sunshine	26	Yozora no Mukou	32	Haru yo, Koi
	03	Bell	09	Stutter + Bell	15	ENTERTAINER	21	Space Battleship Yamato	27	Ai wa Katsu		
	04	Yelp	10	Synthesized Melody	16	AMAZING GRACE	22	Oshiete	28	TRUTH		
	05	Rapid Hi-Lo	11	Chime	17	Maiden with the flaxen hair	23	Makenai de	29	Guts Daze!!		
	06	Melody Chime	12	Call Sign	18	Aux Champs-Elysees	24	"Rocky" Theme Song	30	Odoru Ponpokorin		
Type D	01	Beep	07	Synthesized Piano	13	While listening to Olivia	19	HAPPY BIRTHDAY	25	Schubert's Lullaby	31	When the Saints Go Marching In
	02	Stutter	08	Synthesized Bell	14	September	20	HIHO	26	Rudolph the Red-nosed Reindeer	32	Londonderry Aire
	03	Bell	09	Chime	15	Douyobi no Koibito	21	I've been working on the Railroad	27	She Wore a Yellow Ribbon		
	04	Yelp	10	Call Sign	16	Aki no Kihai	22	The Bear Song	28	My Darling Clementine		
	05	Rapid Hi-Lo	11	Runner	17	Surf Tengoku, Ski Tengoku	23	Toys Go Cha-Cha-Cha	29	Yellow Rose of Texas		
	06	Melody Chime	12	Mamotte Agetai	18	Iro, White Blend	24	Konnako Irukana	30	Yankee Doodle		
Type E	01	Beep	07	Synthesized Piano	13	Train Ride	19	Ringing Phone	25	Annie Laurie	31	Ave Maria
	02	Stutter	08	Synthesized Bell	14	Galloping Hi-Lo	20	Two Tone	26	London Bridge is falling down	32	Grandfather's Clock
	03	Bell	09	Stutter + Bell	15	Alien Chatter	21	Alarm Clock	27	Mary had a little Lamb		
	04	Yelp	10	Synthesized Melody	16	Falling Crystals	22	Ringing Hi-Lo	28	Camptown Races		
	05	Rapid Hi-Lo	11	Chime	17	Inverted Reveille	23	Fur Elise	29	Amaryllis		
	06	Melody Chime	12	Call Sign	18	Galactic Motor	24	Minuet in Gmjr	30	Mozart Symphony No.40		

### Sound Group List (at the time of \* factory shipments setup : Group A)

Sound Group	Group A (*)	Group B	Group C	Group D	Group E	Group F	Group G	Group H	
Sound Type / Channel									
Type A	CH1	Fur Elise	Mary had a little Lamb	Amaryllis	Grandfather's Clock	Spanish Romance	Mary had a little Lamb	Beep	Use an SD Card to freely select a melody. Group A is the default setting upon factory shipment.
	CH2	A Maiden's Prayer	Camptown Races	Mozart Symphony No.40	Ave Maria	Camptown Races	Mozart Symphony No.40	Stutter	
	CH3	Minuet in Gmjr	Cuckoo	Quiet Lakeside	Daydream Believer	Minuet in Gmjr	Hol-Di-Li-Dia	Bell	
	CH4	Annie Laurie	Village Blacksmith	Mountain Musician	London Bridge is falling down	Ave Maria	Daydream Believer	Yelp	
	CH5	London Bridge is falling down	On the Avignon Bridge	Spanish Romance	Bell	Stutter + Bell	Rapid Hi-Lo	Rapid Hi-Lo	
	CH6	Hol-Di-Li-Dia	Daydream Believer	Katyuscha	Yelp	Synthesized Melody	Melody Chime	Melody Chime	
	CH7	Chime	Chime	Chime	Synthesized Piano	Synthesized Piano	Synthesized Piano	Synthesized Piano	
	CH8	Call Sign	Call Sign	Call Sign	Synthesized Bell	Synthesized Bell	Synthesized Bell	Synthesized Bell	
Type C	CH1	Can't take my eyes off of You	Canon	I Don't Want to Miss a Thing	Ima sugu Kiss Me	Maiden with the flaxen hair	Beep	Odoru Ponpokorin	Use an SD Card to freely select a melody. Group A is the default setting upon factory shipment.
	CH2	Top of the World	La-la Sunshine	Yozora no Mukou	Haru yo, Koi	Makenai de	Stutter	Ai wa Katsu	
	CH3	ENTERTAINER	Space Battleship Yamato	Ai wa Katsu	Space Battleship Yamato	Guts Daze!!	Stutter + Bell	TRUTH	
	CH4	AMAZING GRACE	Oshiete	TRUTH	La-la Sunshine	Top of the World	Synthesized Melody	Aux Champs-Elysees	
	CH5	Maiden with the flaxen hair	Makenai de	Guts Daze!!	Can't take my eyes off of You	Canon	Synthesized Piano	AMAZING GRACE	
	CH6	Aux Champs-Elysees	"Rocky" Theme Song	Odoru Ponpokorin	"Rocky" Theme Song	Haru yo, Koi	Synthesized Bell	Yozora no Mukou	
	CH7	Chime	Chime	Chime	Chime	Chime	Chime	Chime	
	CH8	Call Sign	Call Sign	Call Sign	Call Sign	Call Sign	Call Sign	Call Sign	
Type D	CH1	Runner	HAPPY BIRTHDAY	She Wore a Yellow Ribbon	Yellow Rose of Texas	Runner	Surf Tengoku, Ski Tengoku	Douyobi no Koibito	Use an SD Card to freely select a melody. Group A is the default setting upon factory shipment.
	CH2	Mamotte Agetai	HIHO	My Darling Clementine	Yankee Doodle	Iro, White Blend	Konnako Irukana	I've been working on the Railroad	
	CH3	While listening to Olivia	I've been working on the Railroad	Yellow Rose of Texas	When the Saints Go Marching In	Schubert's Lullaby	While listening to Olivia	She Wore a Yellow Ribbon	
	CH4	September	The Bear Song	Yankee Doodle	Londonderry Aire	HIHO	Rudolph the Red-nosed Reindeer	Yankee Doodle	
	CH5	Douyobi no Koibito	Toys Go Cha-Cha-Cha	When the Saints Go Marching In	Beep	Bell	Rapid Hi-Lo	Synthesized Piano	
	CH6	Aki no Kihai	Konnako Irukana	Londonderry Aire	Stutter	Yelp	Melody Chime	Synthesized Bell	
	CH7	Surf Tengoku, Ski Tengoku	Schubert's Lullaby	Runner	Chime	Chime	Chime	Chime	
	CH8	Iro, White Blend	Rudolph the Red-nosed Reindeer	Mamotte Agetai	Call Sign	Call Sign	Call Sign	Call Sign	
Type E	CH1	Fur Elise	Minuet in Gmjr	Fur Elise	Alien Chatter	Train Ride	Rapid Hi-Lo	Beep	Use an SD Card to freely select a melody. Group A is the default setting upon factory shipment.
	CH2	Minuet in Gmjr	Annie Laurie	London Bridge is falling down	Falling Crystals	Galloping Hi-Lo	Chime	Stutter	
	CH3	Annie Laurie	Amaryllis	Mary had a little Lamb	Inverted Reveille	Inverted Reveille	Stutter	Bell	
	CH4	London Bridge is falling down	Mozart Symphony No.40	Camptown Races	Galactic Motor	Galactic Motor	Ringing Phone	Yelp	
	CH5	Mary had a little Lamb	Grandfather's Clock	Amaryllis	Ringing Phone	Alarm Clock	Stutter + Bell	Rapid Hi-Lo	
	CH6	Camptown Races	Ave Maria	Grandfather's Clock	Two Tone	Ringing Hi-Lo	Synthesized Melody	Melody Chime	
	CH7	Chime	Chime	Chime	Alarm Clock	Synthesized Piano	Synthesized Piano	Synthesized Piano	
	CH8	Call Sign	Call Sign	Call Sign	Ringing Hi-Lo	Synthesized Bell	Synthesized Bell	Synthesized Bell	

Although copyright licensing has been acquired for the A, C, and D type melody/alarms in Japan for our company, since the copyright licensing for countries outside Japan has not been acquired, if used in countries other than Japan, there is a necessity to acquire copyright licensing for the customer.