

# ST07

## Specification



### Features

- Steel / Aluminum Alloy / Plastic
- Support Flat Panel Size 24"~32"
- Swivel Max +/-15°
- Tilt Max +/-15°
- Rotate (Pivot) 360°
- Hight Adjustment
- Cable Management

Panel	Material	Steel / Aluminum Alloy / Plastic
	Screw Type	M4
	Max. Wall mount hole pitch	100x100mm / 75x75mm
	Swivel	Max. +/-15° (For each "Hinge")
	Tilt	Max +/-15° (For each "Hinge")
	Rotate (Pivot)	360° (For each "Hinge")
	Support Max. Weight	15Kg
	Dimension (W*D*H)	924*307*470 mm (36.38" x 12.09" x 18.50")
	Support max. weight	15Kg (33.07 lbs) (For each "Hinge")
	Support flat panel size	≤ 24"

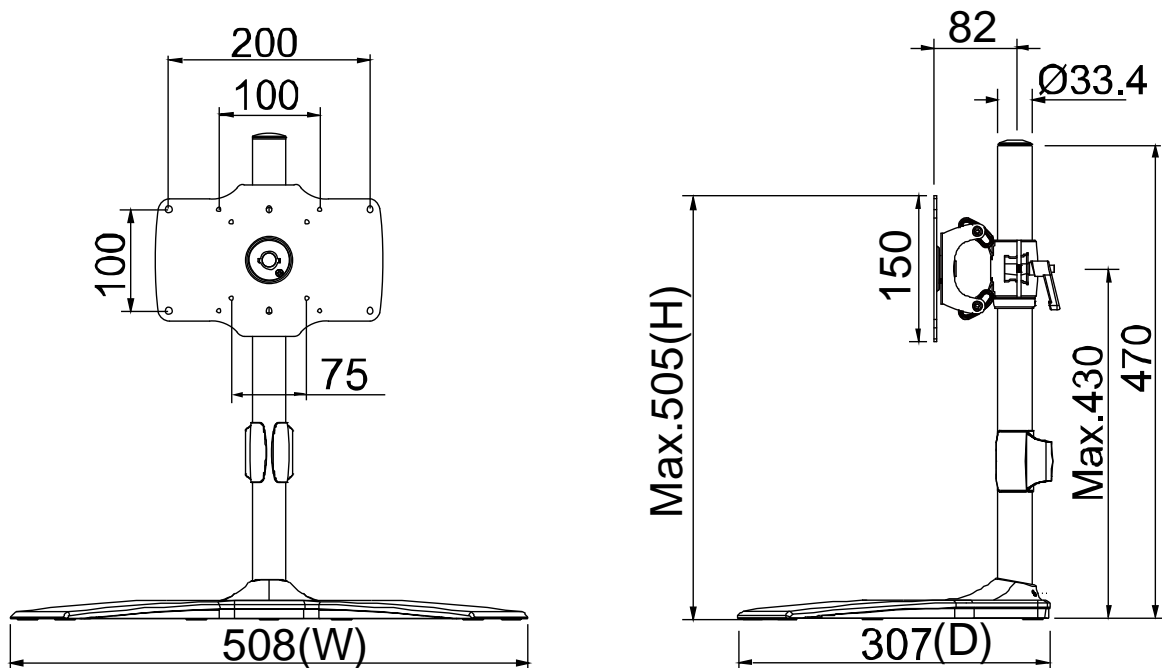

**Winsonic**®

Winsonic Electronics CO.,LTD. TEL:886-3-3704789 FAX:886-3-3704722 E-mail:sales@ewinsonic.com  
No.290-1 Wun-Jhong Rd. Taoyuan City, Taoyuan Taiwan R.O.C

Online Download

[www.ewinsonic.com](http://www.ewinsonic.com)