

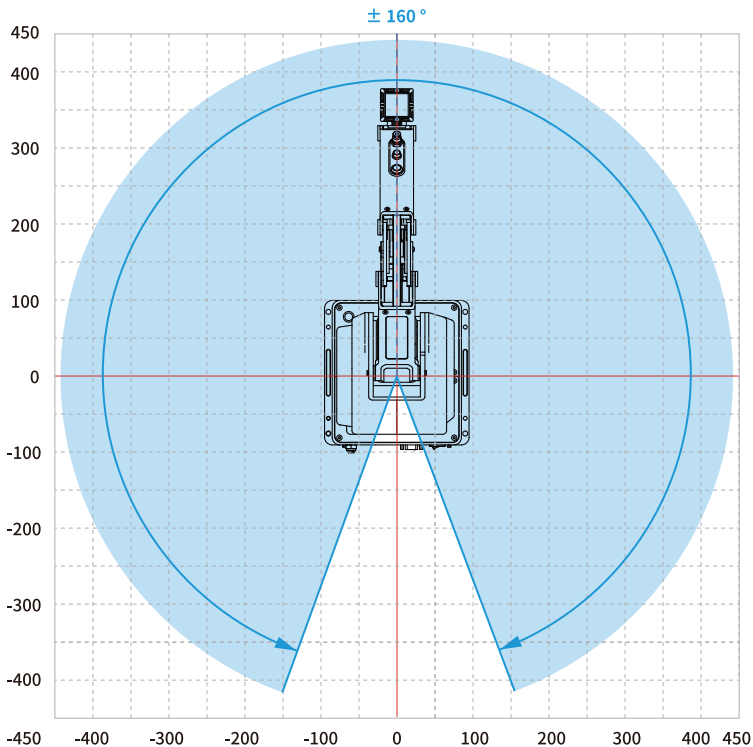

## DOBOT MG400

中国·深圳市越疆科技有限公司  
Shenzhen Yuejiang Technology Co.,Ltd |China  
www.dobot.cc

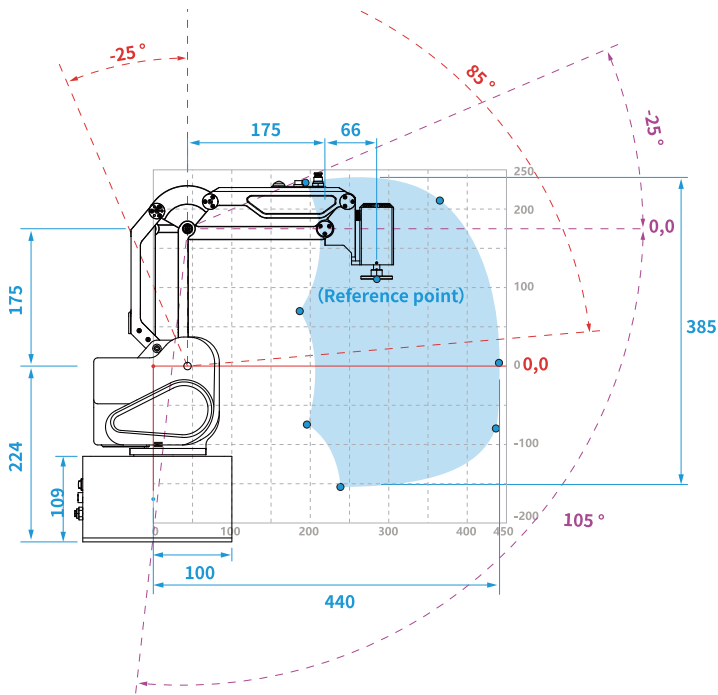

**Product Name** DOBOT MG400  
**Product Model** DT-MG400-4R075-01

**Controlled Axes** 4  
**Max. Load** 500 g (Max. 750 g)  
**Max. Reach** 440 mm  
**Repeatability** ±0.05 mm

Motion Parameters	Joint	Motion Range	Max. Speed
	J1	±160°	300 °/s
	J2	-25° ~ 85°	300 °/s
	J3	-25° ~ 105°	300 °/s
	J4	-360° ~ 360°	300 °/s

**Power Input** 100~240 V AC, 50/60 Hz  
**Rated Voltage** 48 V  
**Rated Power** 240 W  
**Communication** TCP/IP, Modbus TCP  
**Installation** Desktop  
**Weight** 8 kg  
**Base Dimension** 190 mm × 190 mm  
**work environment** 0 °C~40 °C  
**Software** DobotStudio 2020, SCStudio

### Interface

<b>Base:</b>	Digital Input	16
	Digital Output	16
	Ethernet	2
	USB 2.0	2
	Encoder Input	1
<b>End:</b>	Digital Input	2
	Digital Output	2
	Air way	1

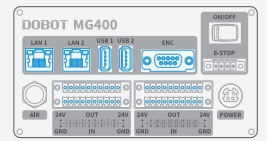

### Mounting Drawing

