

Y-Con Cover-20-TC

ASSEMBLY INSTRUCTIONS
MONTAGEANLEITUNG

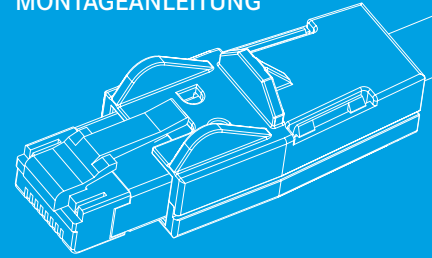

Y-Con Cover-20-TC



01 Strip the cable to the appropriate length
Kabel auf passende Länge abisolieren

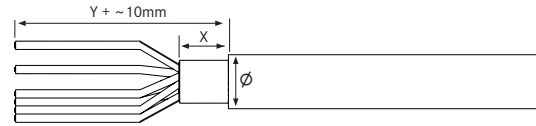

03

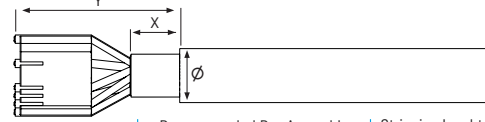

Cable diameter Kabeldurchmesser	Recommended Pre-Assembly Empfohlene Vorbereitung		Stripping length Abisolierlänge
	X ± 1.0mm	Y ± 1.0mm	A ± 1.0mm
∅6.1 - 6.6mm	X=15.0mm	Y=30.0mm	A=11.5mm
∅6.7 - 7.1mm	X=18.5mm	Y=33.0mm	A=15.0mm

02 Thread single wires into the insert as shown
Einzellitzen, wie abgebildet, in Insert einfädeln

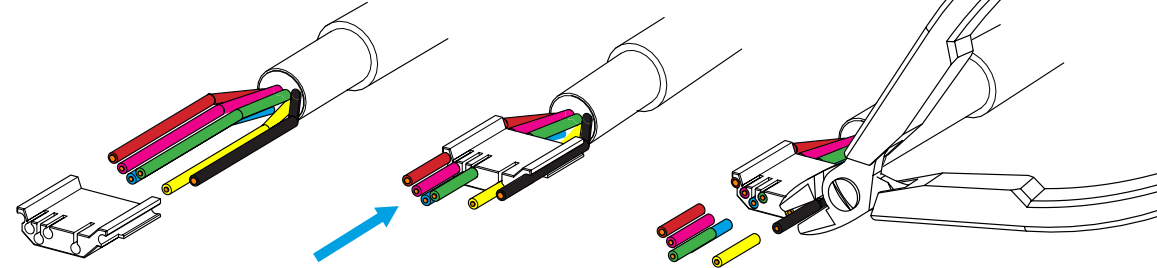
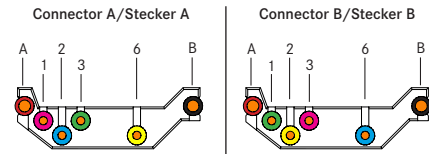

04 Insert the prepared cable into the plug using the Y-Con Tool-30 until it stops
Vorbereitetes Kabel mit Hilfe des Y-Con Tool-30 bis zum Anschlag in den Plug einführen

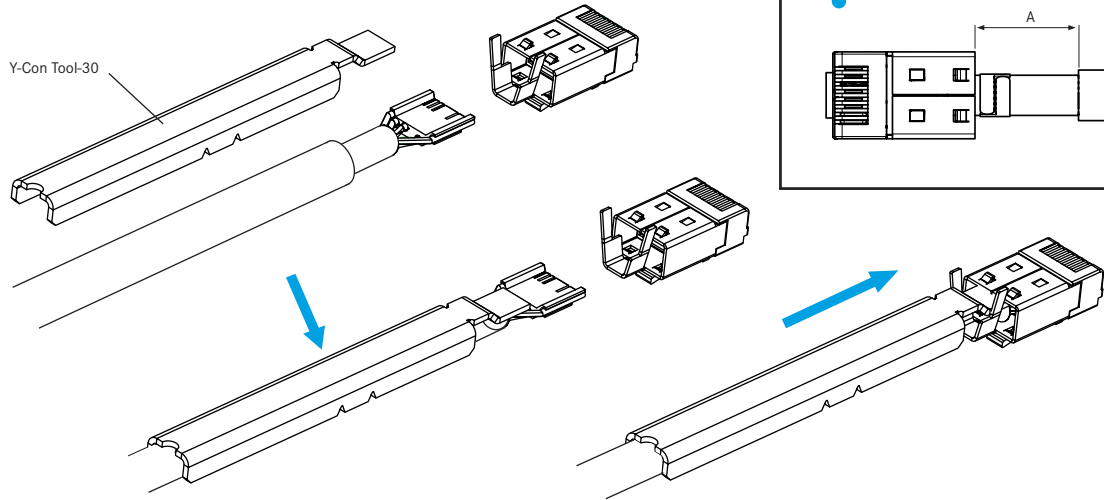

Check dimension A before crimping!
Maß A vor dem Crimpen prüfen!

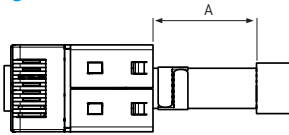

05 Connect the plug with the crimping tool as shown
Plug mittels Crimpzange, wie abgebildet, mit dem Kabel verbinden

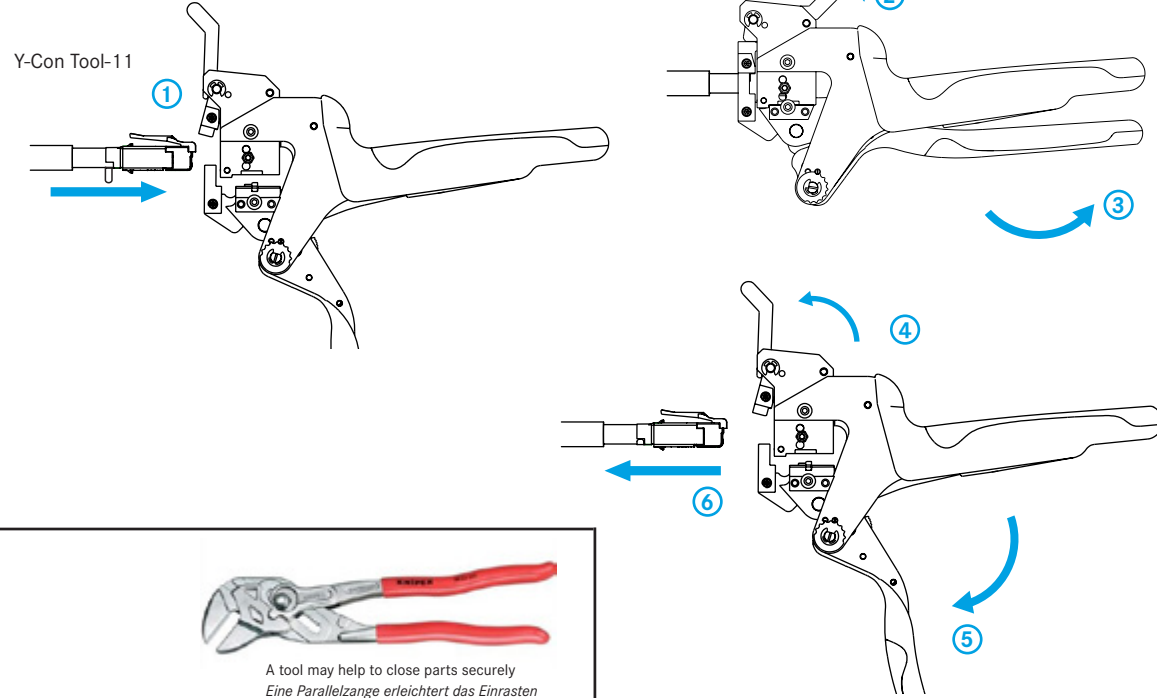

06 Put the assembled RJ45 into cover 20 as shown and compress
Assemblierten RJ45, wie abgebildet, in Cover 20 einlegen und zusammendrücken

Watch out! The tab must necessarily point upwards
Achtung! Das Hebel muss unbedingt nach oben zeigen

Tab/Hebel

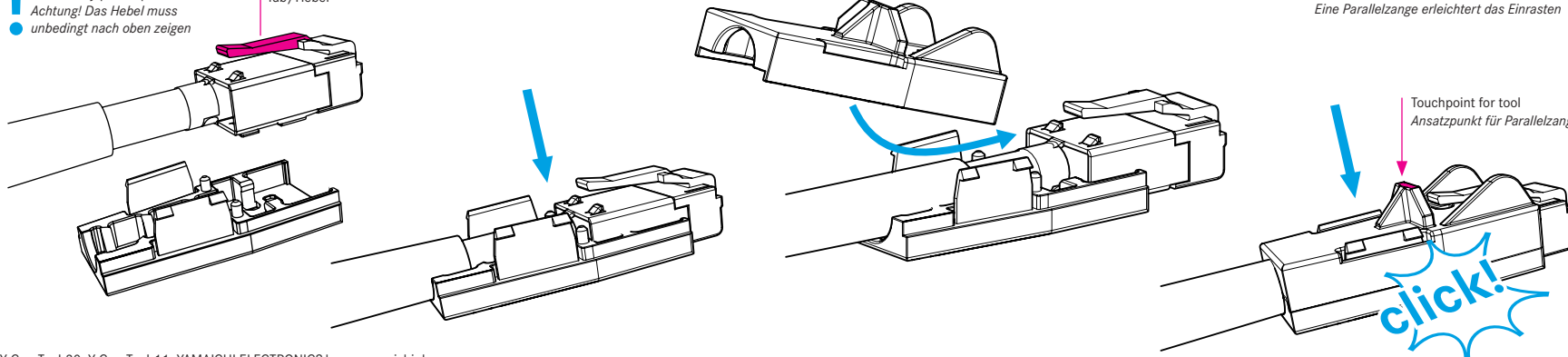

A tool may help to close parts securely
Eine Parallelzange erleichtert das Einrasten

Touchpoint for tool
Ansatzpunkt für Parallelzange

**READY TO
PLUG**

01 Insert a flat screwdriver into the clip lock
Einen flachen Schraubendreher in den Clipverschluß einführen

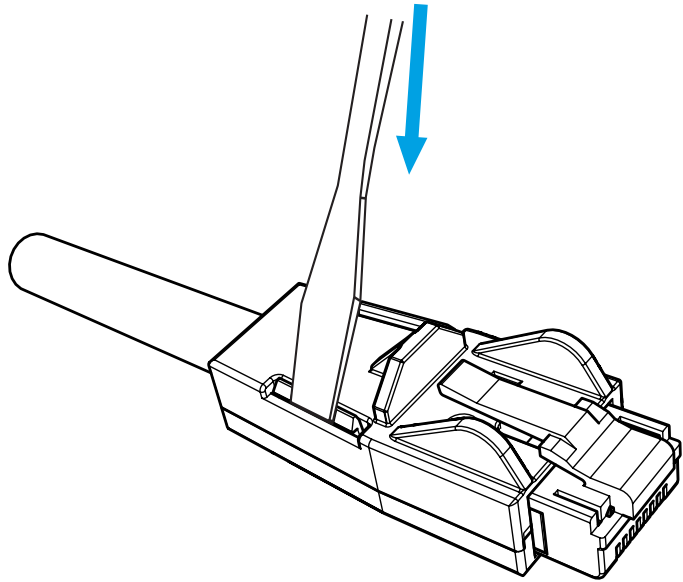

02 Insert a second screwdriver into the groove between the Halfshells
Zweiten Schraubendreher in die Nut zwischen den Halbschalen schieben

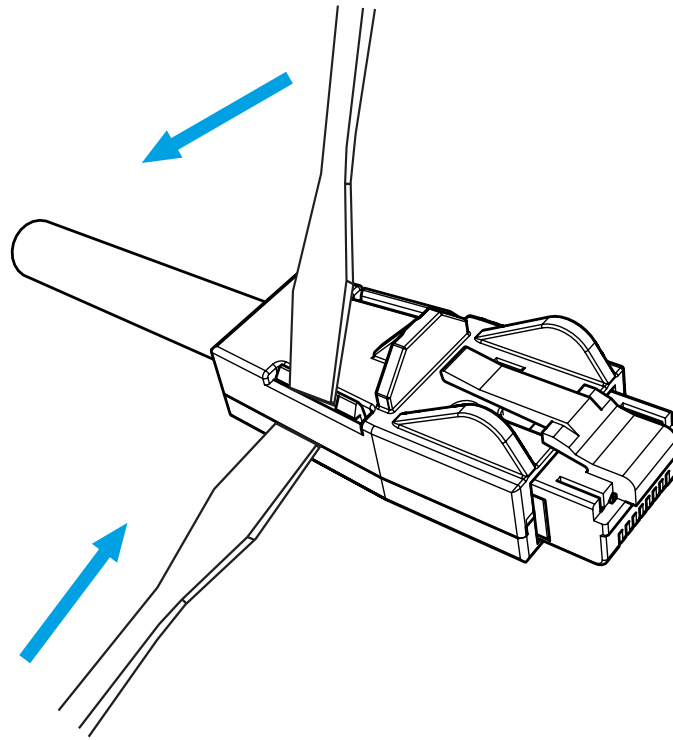

03 Turn the second screwdriver to separate the Halfshells
Zweiten Schraubendreher drehen und so die Halbschalen trennen

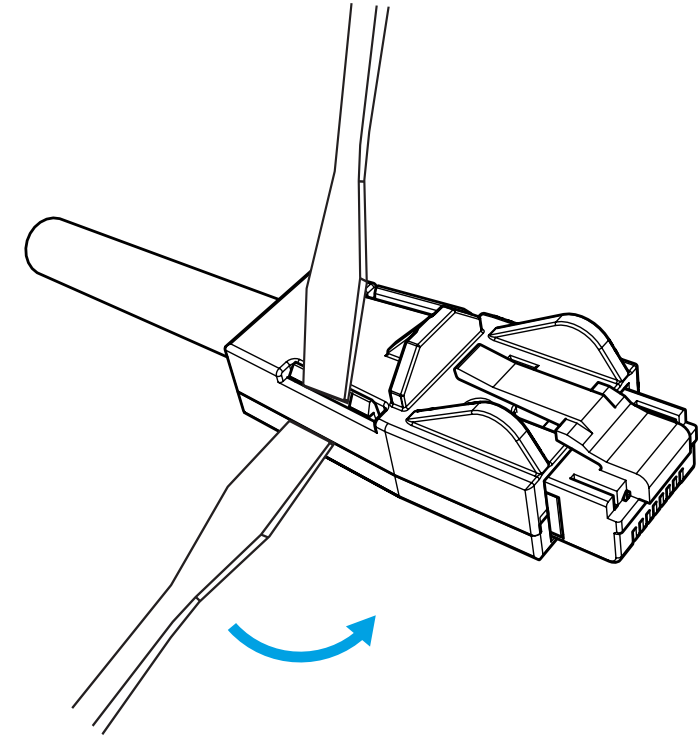

04 Pull off the upper half-shell backwards and upwards
Obere Halbschale nach hinten oben abziehen

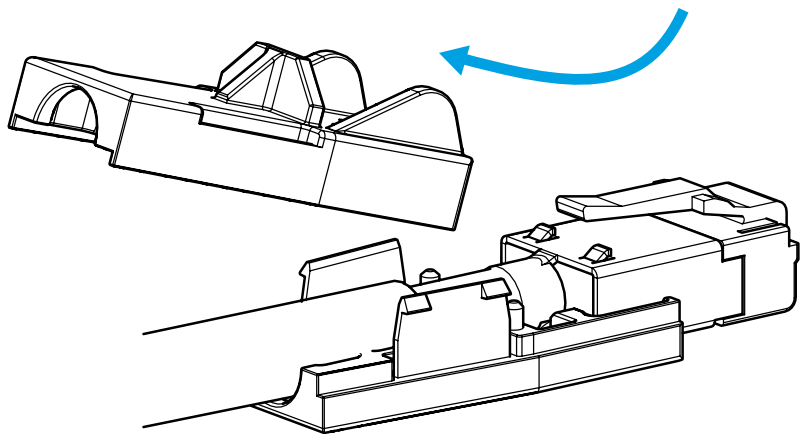

05 Lift out the plug with the cable
Plug mit Kabel herausheben

